

DATA SHEET

SA57001-XX

Microminiature, low power consumption,
low dropout regulator

Product data
Supersedes data of 2003 Mar 20

2003 Oct 16

Microminiature, low power consumption, low dropout regulator

SA57001-XX

GENERAL DESCRIPTION

The SA57001-XX is a series of micro-miniature linear regulators providing fixed output voltages with a precision accuracy of $\pm 2\%$ at output currents up to 200 mA. The regulator is designed to serve as a post regulator in microprocessor power supplies. The device has an ON/OFF pin for output On/Off control, and a Noise pin which can be used to bypass the internal voltage reference node for enhanced noise reduction.

The SA57001 has a dropout voltage of only 0.1 V (typical) while delivering 50 mA of output current. The maximum no load quiescent current is less than 190 μA in the ON state. The device has thermal shutdown and output current limiting circuits to prevent damage from overheating and short circuits. The SA57001 regulator series is available in the small outline 5-lead package (SOP003).

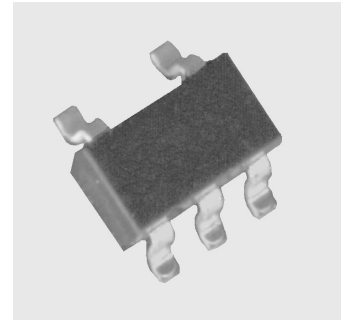

FEATURES

- No load quiescent current of 95 μA
- 0.1 V typical ($I_O = 50 \text{ mA}$) dropout voltage
- 70 dB typical ripple rejection
- 200 mA maximum output current
- 35 μV_{rms} (typical)
- Preset output voltages of 2.0, 2.5, 2.8, 3.0, 3.1, 3.3, 3.6, 4.5, 4.8, 5.0 V available
- Output current limiting
- Thermal shutdown protection
- Output ON/OFF control.

APPLICATIONS

- Cordless phones
- Portable minidisks
- Other battery-operated equipment.

SIMPLIFIED SYSTEM DIAGRAM

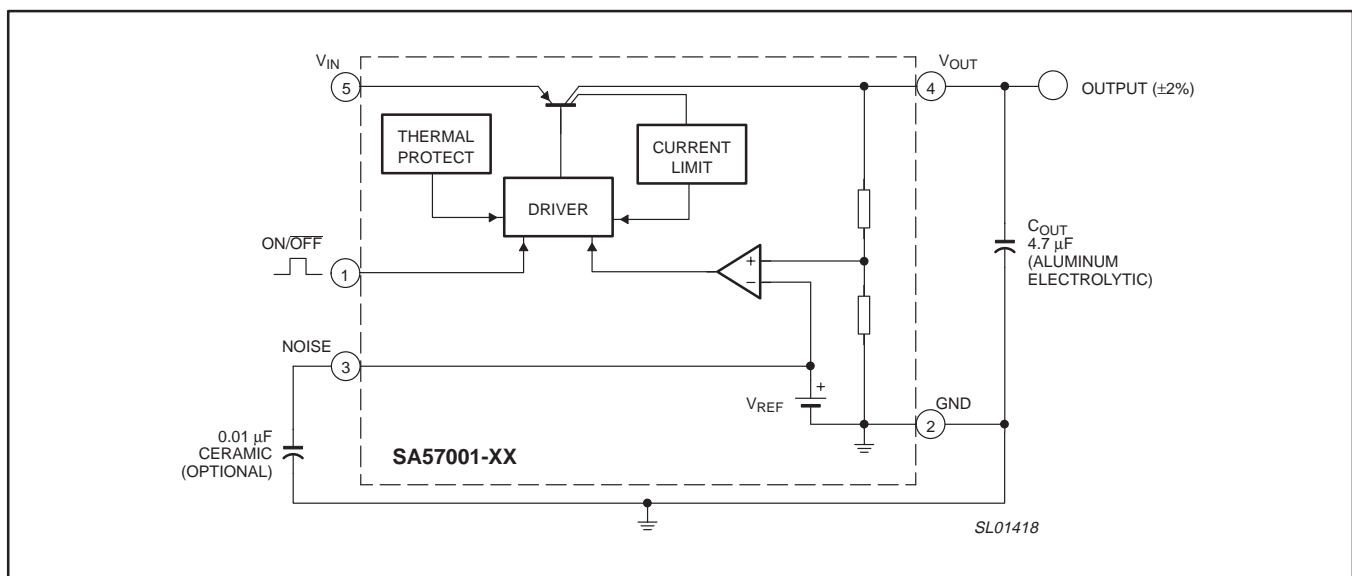

Figure 1. Simplified system diagram.

Microminiature, low power consumption, low dropout regulator

SA57001-XX

ORDERING INFORMATION

TYPE NUMBER	PACKAGE	VERSION	TEMPERATURE RANGE
	DESCRIPTION		
SA57001-XXGW	plastic small outline package; 5 leads (see dimensional drawing)	SOP003	-40 to +85 °C

NOTE:

The device has ten voltage output options, indicated by the **XX** on the Type Number.

XX	VOLTAGE (Typical)
20	2.0 V
25	2.5 V
28	2.8 V
30	3.0 V
31	3.1 V
33	3.3 V
36	3.6 V
45	4.5 V
48	4.8 V
50	5.0 V

Marking code

Each device is marked with a four letter code. The first three letters designate the product. The fourth, represented by an 'x', designates the date tracking code.

Part	Marking
SA57001-20GW	ADKx
SA57001-25GW	AMFx
SA57001-28GW	ADJx
SA57001-30GW	ADGx
SA57001-31GW	ADFx
SA57001-33GW	ADEx
SA57001-36GW	ADHx
SA57001-45GW	ADDx
SA57001-48GW	ADLx
SA57001-50GW	ADCx

PIN CONFIGURATION

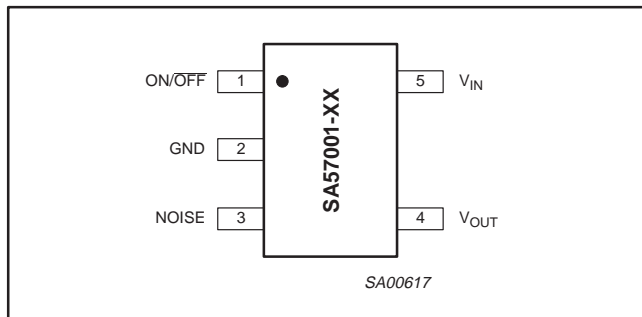

Figure 2. Pin configuration.

PIN DESCRIPTION

PIN	SYMBOL	DESCRIPTION
1	ON/OFF	Output ON/OFF control pin.
2	GND	Circuit ground pin.
3	NOISE	Provides option of externally bypassing the internal voltage reference node for enhanced noise reduction.
4	V _{OUT}	Voltage regulator output.
5	V _{IN}	Input supply voltage to regulator.

MAXIMUM RATINGS

SYMBOL	PARAMETER	MIN.	MAX.	UNIT
V _{IN}	Input supply voltage	-0.3	12	V
T _{oper}	Operating ambient temperature range	-20	+75	°C
T _j	Operating junction temperature	-	140	°C
T _{stg}	Storage temperature	-40	+125	°C
P _D	Power dissipation	-	150	mW
R _{th(j-a)}	Thermal resistance from junction to ambient	-	140	°C/W
V _{ESD1}	ESD damage threshold (Human Body Model); Note 1	-	2000	V
V _{ESD2}	ESD damage threshold (Machine Model); Note 2	-	200	V
T _{solder}	Soldering temperature; Note 3	-	230	°C

NOTES:

1. Performed in accordance with Human Body Model (CZap = 100 pF, RZap = 1500 Ω).
2. Performed in accordance with Machine Model (CZap = 100 pF, RZap = 0 Ω).
3. 60 second maximum exposure for SMD Reflow temperatures above 183 °C.

Microminiature, low power consumption, low dropout regulator

SA57001-XX

DC ELECTRICAL CHARACTERISTICS

$T_{amb} = 25\text{ °C}$, unless otherwise specified.

SYMBOL	PARAMETER	CONDITIONS	MIN.	TYP.	MAX.	UNIT
V_{OUT}	Output voltage	$V_{IN} = V_{OUT} + 1.0\text{ V}$; $I_{OUT} = 30\text{ mA}$	$V_{OUT} - 2.0\%$	V_{OUT}	$V_{OUT} + 2.0\%$	V
I_{LIM}	Output current limit		200	240	–	mA
I_{Q1}	Quiescent current (circuit ON)	$V_{IN} = V_{OUT} + 1.0\text{ V}$; ON/OFF = V_{IN} ; $I_{OUT} = 0\text{ mA}$	–	95	190	μA
I_{Q2}	Quiescent current (circuit OFF)	$V_{IN} = V_{OUT} + 1.0\text{ V}$; ON/OFF = 0 V	–	–	0.1	μA
$V_{IN} - V_{OUT}$	Dropout voltage (Note 1)	$V_{IN} = V_{OUT} + 0.2\text{ V}$; $I_{OUT} = 50\text{ mA}$	–	0.1	0.2	V
Reg_{line}	Line regulation	$V_{OUT} + 1.0\text{ V} \leq V_{IN} \leq V_{OUT} + 10\text{ V}$; $I_{OUT} = 50\text{ mA}$	–	10	20	mV
Reg_{load}	Load regulation	$V_{IN} = V_{OUT} + 1.0\text{ V}$; $0\text{ mA} \leq I_{OUT} \leq 100\text{ mA}$	–	30	60	mV
TCV_o	Temperature coefficient of output voltage	$-20\text{ °C} \leq T_j \leq 75\text{ °C}$; $V_{IN} = V_{OUT} + 1.0\text{ V}$; $I_{OUT} = 30\text{ mA}$	–	100	–	$\mu\text{V}/\text{°C}$
RR	Ripple rejection ratio	$V_{IN} = V_{OUT} + 1.0\text{ V}$; $I_{OUT} = 30\text{ mA}$; $V_{IN(Ripple)} = 1.0\text{ V}_{P-P}$; $f = 120\text{ Hz}$	50	70	–	dB
V_n	Output noise voltage	$V_{IN} = V_{OUT} + 1.0\text{ V}$; $I_{OUT} = 30\text{ mA}$; $20\text{ Hz} \leq f \leq 80\text{ kHz}$; $C_n = 0.01\text{ }\mu\text{F}$	–	35	–	μV_{rms}
$I_{ON/OFF}$	ON/OFF input current	$V_{ON/OFF} = 1.6\text{ V}$	–	5.0	10	μA
$V_{ON/OFF(H)}$	ON/OFF threshold (logic HIGH)		1.6	–	$V_{IN} - 0.3\text{ V}$	V
$V_{ON/OFF(L)}$	ON/OFF threshold (logic LOW)		–0.3	–	0.4	V
T_{LIM}	Thermal shutdown		–	125	–	°C

NOTE:

- Dropout voltage is a measure of the minimum input/output differential voltage at the specified output current.

Microminiature, low power consumption, low dropout regulator

SA57001-XX

TYPICAL PERFORMANCE CURVES

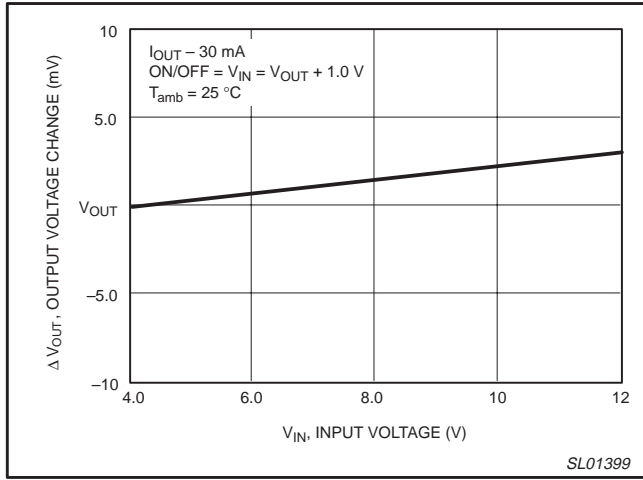

Figure 3. Normalized line regulation versus input voltage.

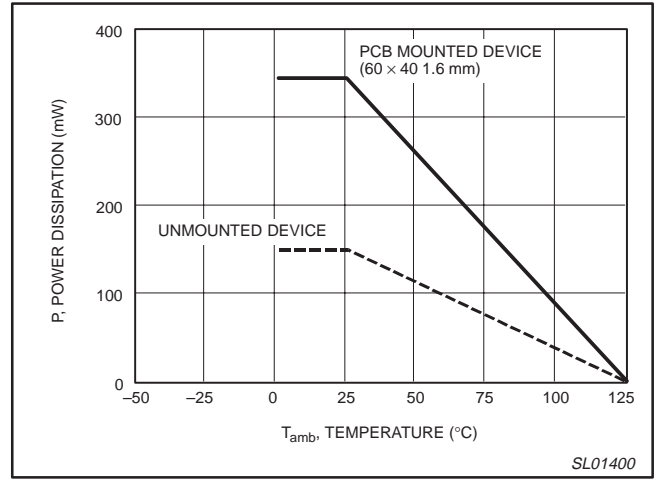

Figure 4. Power dissipation versus temperature.

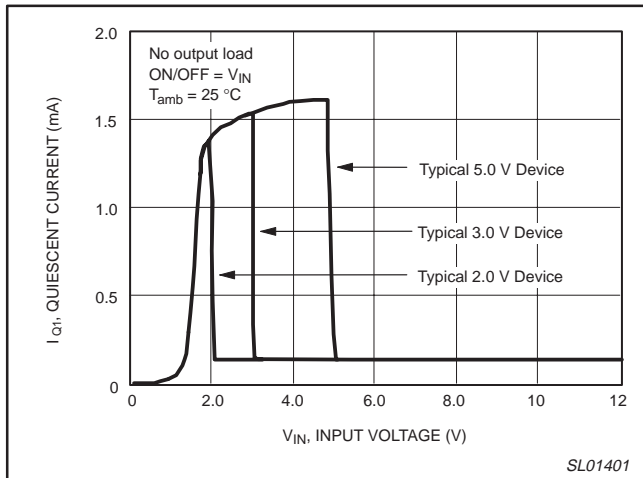

Figure 5. Quiescent current versus input voltage.

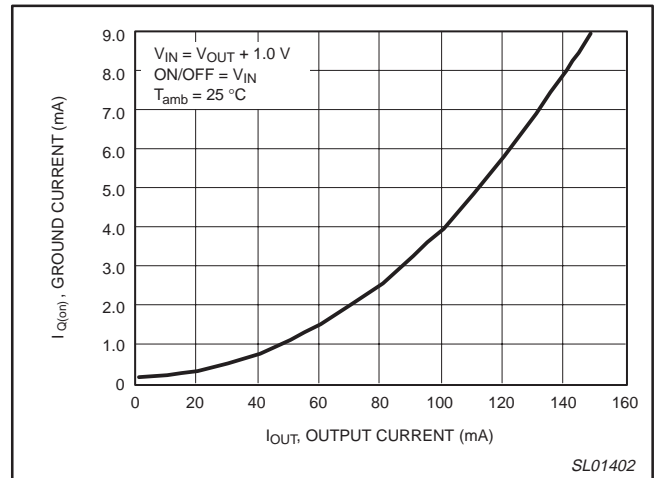

Figure 6. Ground current versus output current.

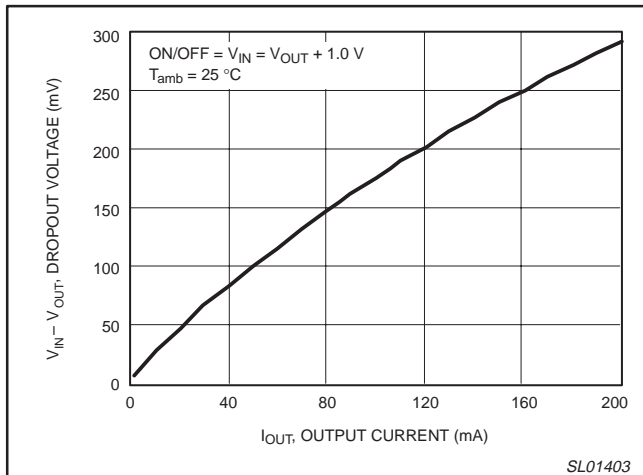

Figure 7. Dropout voltage versus output current.

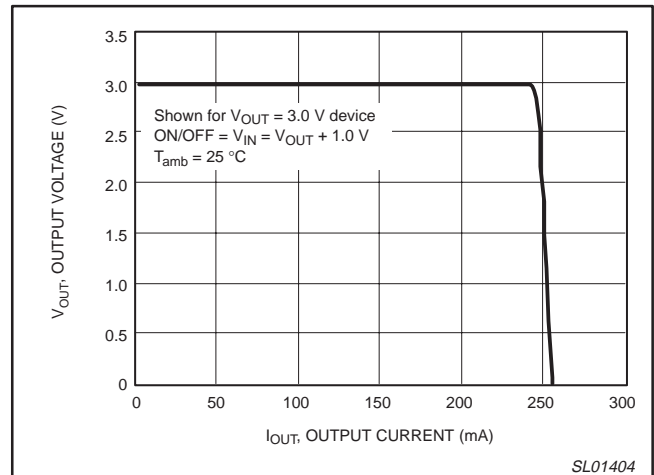

Figure 8. Typical output current limit.

Microminiature, low power consumption, low dropout regulator

SA57001-XX

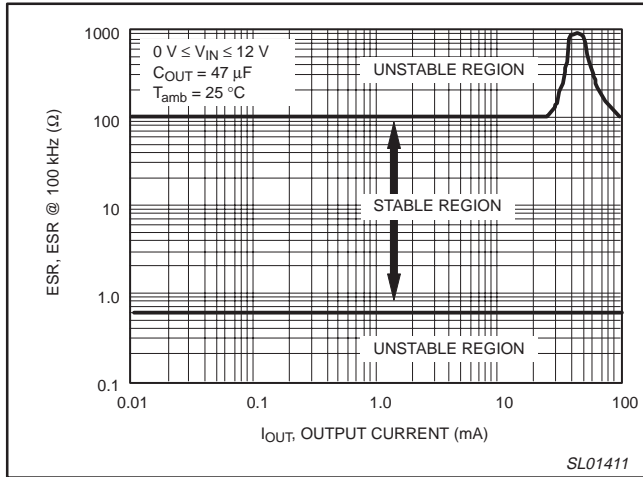

Figure 9. ESR stability versus output current.

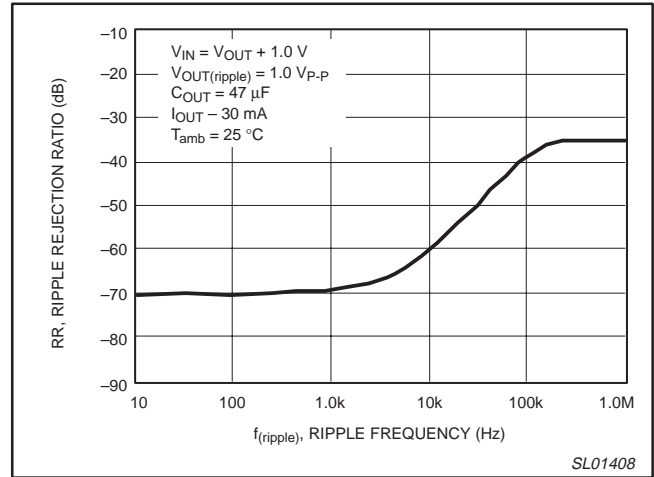

Figure 10. Ripple rejection ratio versus frequency.

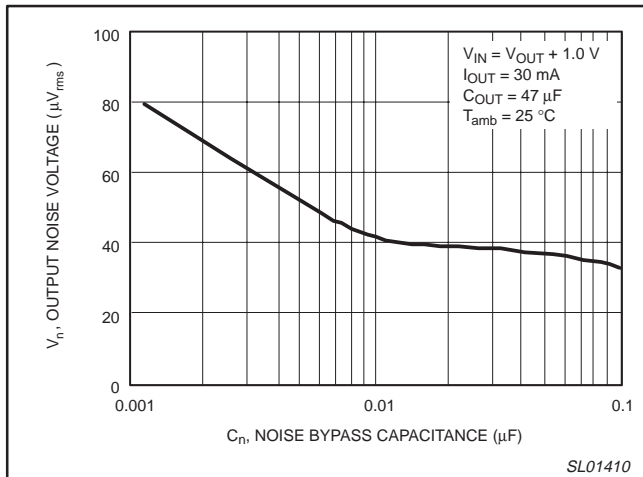

Figure 11. Output noise versus noise capacitance.

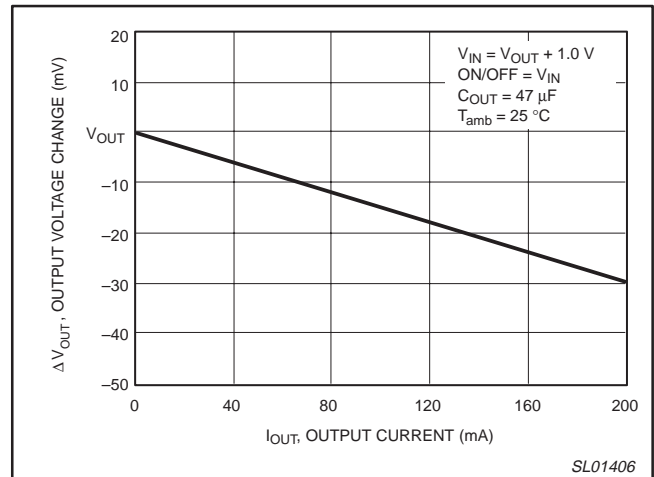

Figure 12. Normalized load regulation.

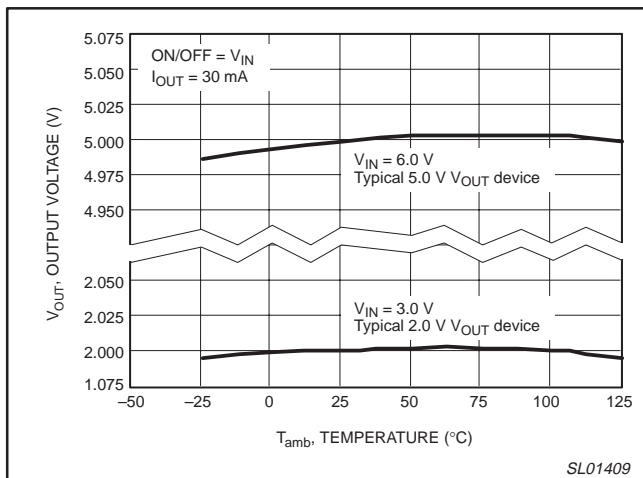

Figure 13. Output voltage versus temperature.

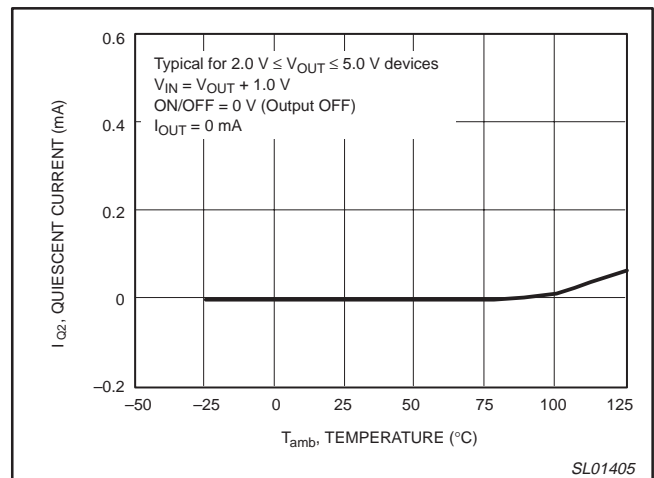

Figure 14. Quiescent current versus temperature.

Microminiature, low power consumption, low dropout regulator

SA57001-XX

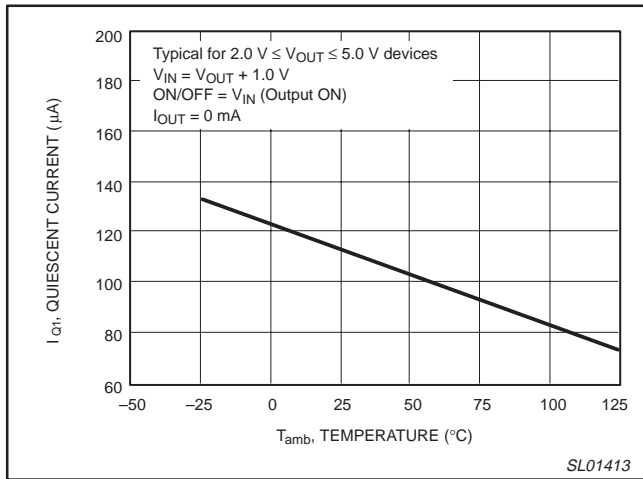

Figure 15. Quiescent current versus temperature.

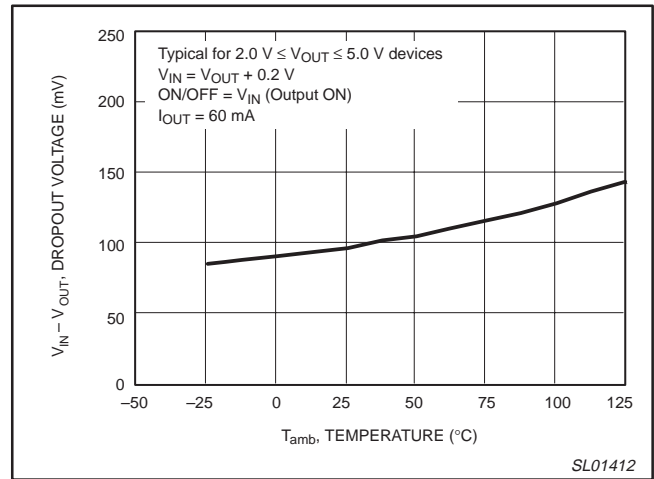

Figure 16. Dropout voltage versus temperature.

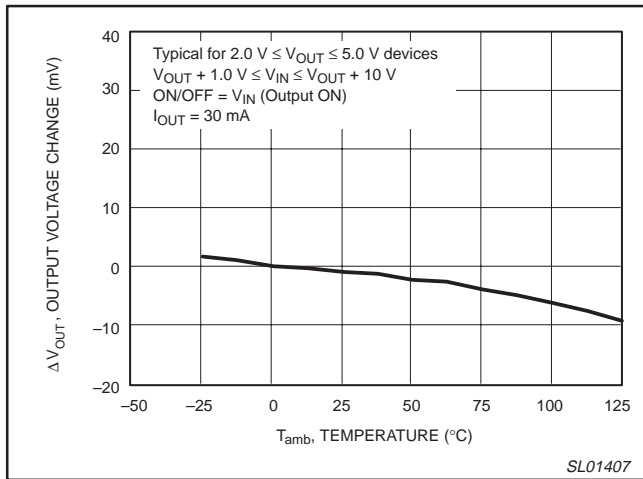

Figure 17. Line regulation versus temperature.

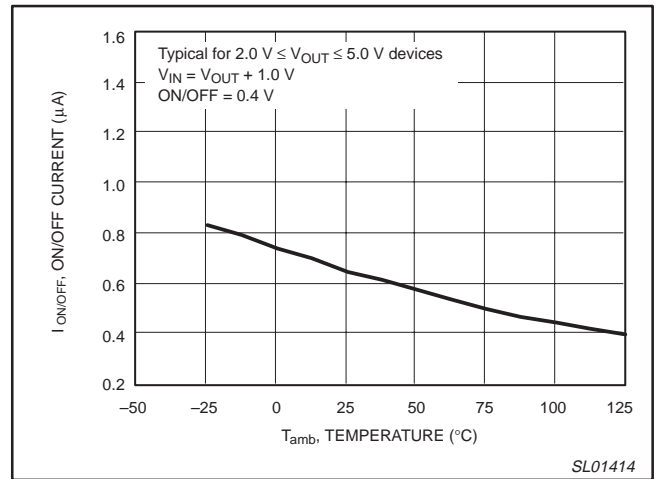

Figure 18. ON/OFF current versus temperature.

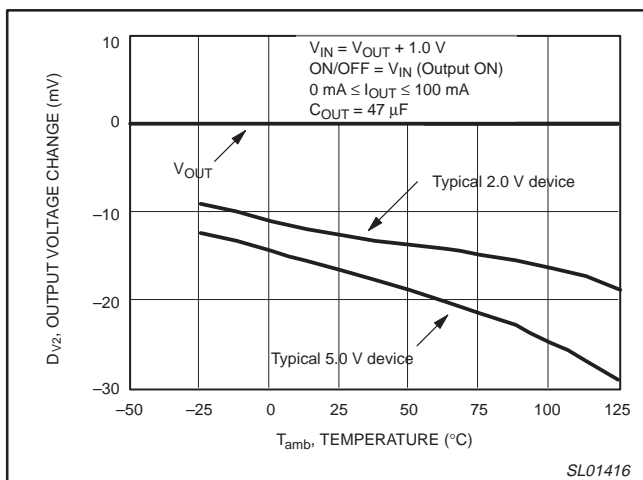

Figure 19. Load regulation variance versus temperature.

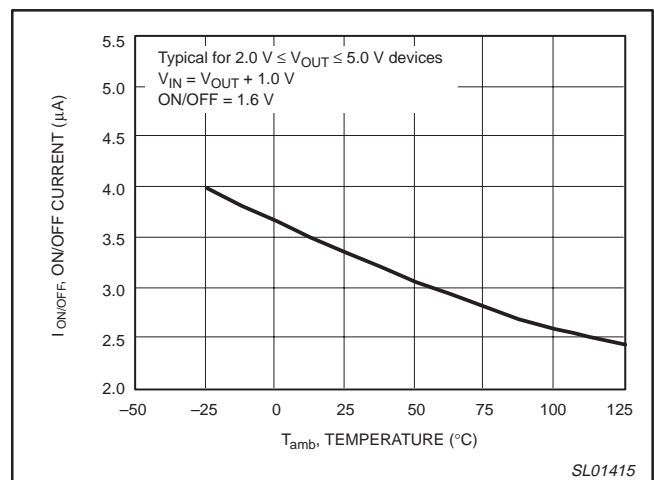

Figure 20. ON/OFF pin current versus temperature.

Microminiature, low power consumption,
low dropout regulator

SA57001-XX

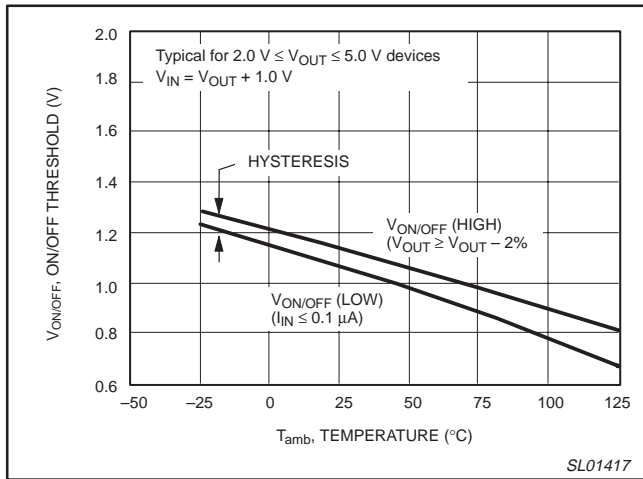

Figure 21. ON/OFF threshold versus temperature.

Microminiature, low power consumption, low dropout regulator

SA57001-XX

TECHNICAL DESCRIPTION

The SA57001 is a family of series regulators incorporating a bandgap reference, two feedback amplifiers, a thermal shutdown circuit, and an output current limiting circuit. Both feedback amplifiers are referenced to the bandgap reference. See the device diagram shown in Figure 22.

A PNP transistor in the device's output serves as the series pass element. The output PNP pass transistor incorporates a dual collector.

The first feedback amplifier monitors the first collector's output voltage through the use of a voltage divider network fed directly from the output. The second collector produces a small current that is proportional to the output current. The proportional current flows through a resistor, generating a second feedback voltage that is proportional to the output current. This voltage is fed to the second feedback amplifier to limit the output current to a safe operating level.

Both feedback amplifiers act on the same control node, to control the PNP pass transistor's conduction. This dual path output monitoring maintains a constant output voltage while also limiting the output current.

Stability factors: Capacitance and ESR

The operating stability of linear regulators is determined by start-up delay, transient response to load currents, and stability of the feedback loop. The SA57001 has a fast transient loop response, with no built-in delay.

Capacitors play an important part in compensating the regulator's output. A 4.7 μF aluminum electrolytic capacitor is recommended for most applications, because they provide good performance with minimal cost. A tantalum capacitor can also be used. Tantalum

capacitors are smaller than electrolytic capacitors of the same capacitance value. Tantalum capacitors also are not prone to dry-out. The electrolyte used in electrolytic capacitors tends to dry out with time, degrading the performance. Avoid using extremely low ESR film or ceramic capacitors to avoid instability problems. See Figure 9, 'ESR stability versus output current'.

Keep in mind that the output capacitor tries to supply any instantaneous increase in load current from its stored energy. Using higher values of capacitance will enhance transient load performance as well as stability. Lowering the ESR of the capacitors will also improve the transient response to load current changes, but it will decrease stability.

Noise reduction

The noise reduction pin of the device is connected to the internal reference voltage node. Bypassing this pin to ground with a capacitor (0.01 μF typical) will reduce the output voltage noise for demanding applications. This also improves the AC performance by increasing ripple rejection.

In addition, bypassing the input pin to ground with a capacitor (0.1 μF typical) will suppress input ripple from the power source.

Thermal overload protection

When the junction temperature reaches approximately 150 $^{\circ}\text{C}$, the thermal sensor signals the shutdown logic to turn off the pass transistor. After the junction temperature has cooled to below the thermal threshold, plus the hysteresis, the sensor signals the shutdown logic to turn the pass transistor on again. This will create a pulsed output during lengthy thermal overloads.

NOTE: Thermal overload protection is to protect the device during fault conditions. Do not exceed the maximum junction-temperature rating of $T_j = +150\text{ }^{\circ}\text{C}$ during continuous operation.

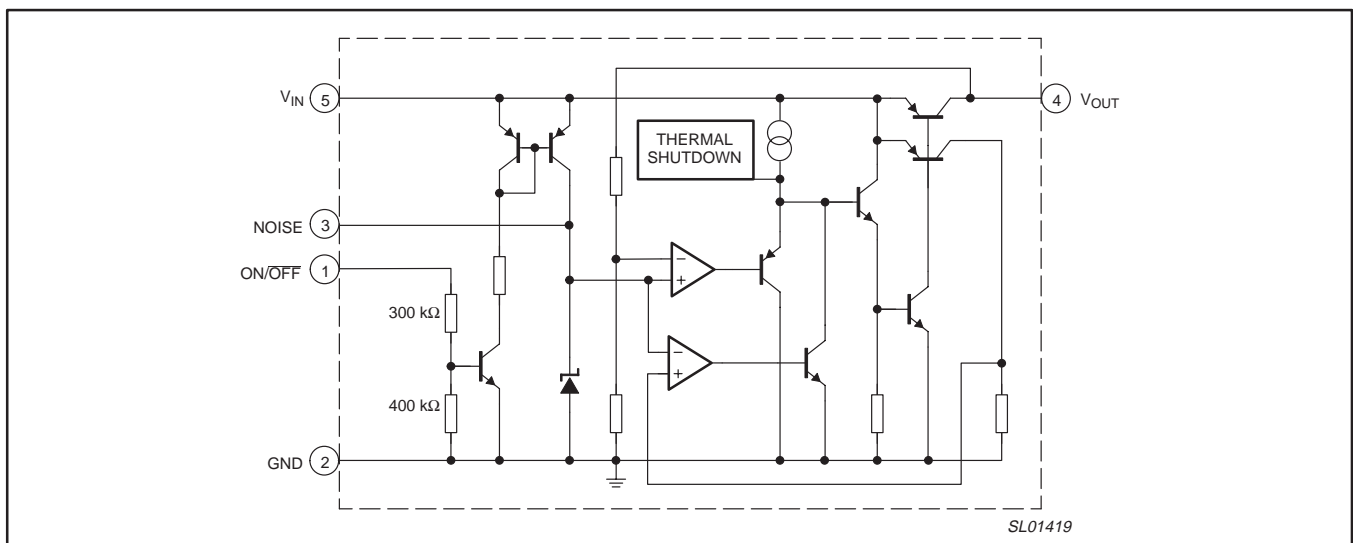

Figure 22. Functional diagram.

Microminiature, low power consumption, low dropout regulator

SA57001-XX

APPLICATION INFORMATION

Power dissipation factors

The thermal performance of linear regulators depends on the following parameters:

- Maximum junction temperature (T_j) in °C
- Maximum ambient temperature (T_{amb}) in °C
- Power dissipation capability of the package in Watts (P_D)
- Junction-to-ambient thermal resistance in °C/W

The Maximum Junction Temperature and Maximum Power Dissipation are both determined by the manufacturer's process and device's design. For the most part the ambient temperature is under the control of the user. The Maximum Ambient Temperature depends on the process used by the manufacturer. The package type and manufacturer's process determines Junction-to-Ambient Thermal Resistance.

These parameters are related to each other as shown in the following equation:

$$T_j = T_{amb} + (P_D \times R_{th(j-a)})$$

The term ($P_D \times R_{th(j-a)}$) represents the temperature rise from the ambient to the internal junction of the device.

Power dissipation calculations

A regulator's maximum power dissipation can be determined by using the following equation:

$$P_{D(max)} = V_{IN(max)} I_G + [V_{IN(max)} - V_{OUT(min)}] I_{OUT(max)}$$

where:

- $V_{IN(max)}$ is the maximum input voltage
- I_G is the maximum Ground Current at maximum output current
- $V_{OUT(min)}$ is the minimum output voltage
- $I_{OUT(max)}$ is the maximum output current

($V_{IN(max)} I_G$) represents heat generated in the device due to internal circuit biasing, leakage, etc. [$V_{IN(max)} - V_{OUT(min)}$] is the input-to-output voltage drop across the device due to the $I_{OUT(max)}$ current. When multiplied by $I_{OUT(max)}$, this represents heat generated in the device due to the output load current. Heat generated by the device represents lost energy (an inefficiency).

The SA57001 device should not be operated under conditions that would cause a junction temperature of 150 °C to be generated because the thermal shutdown protection circuit will shut down the device at or near this temperature.

Heat dissipation factors

Heat generated within the device is removed to the surrounding environment by radiation or conduction along several paths. In general, radiated heat is dissipated directly into the surrounding ambient from the chip package and leads. Conducted heat flows through an intermediate material, such as the leads or thermal grease, to circuit board traces and heat sinks in direct contact with the device's package or leads. The circuit board then radiates this heat to the ambient. For this reason, adequate airflow over the device and the circuit board is important.

The SOT23-5 package is too small to easily use external heat sinks to increase the surface area and enhance the dissipation of generated heat. Heat dissipation must depend primarily on radiated heat into the surrounding environment and the heat flow through the leads into the printed circuit board. Some improvement can be realized by allowing additional exposed copper on the circuit board near the device to serve as heat absorbers and dissipaters for the device.

The overall thermal resistance from junction to the surrounding ambient of the package ($R_{th(j-a)}$) is made up of three series elements and can be thought of as the total resistance of a series electrical circuit. These elements are:

- $R_{th(j-c)}$ = Thermal resistance from Junction-to-Case
- $R_{th(c-s)}$ = Thermal resistance from Case-to-heat Sink
- $R_{th(s-a)}$ = Thermal resistance from heat Sink-to-Ambient

$R_{th(j-a)}$ is based primarily on the package type and the size of the silicon chip used in the device. The composition of package materials plays an important part. High heat conductivity materials produce reduced Junction-to-Case resistances.

$R_{th(c-s)}$ value is based on the package type, heat sink interface, and contact area of the device to the heat sink. The use of thermal grease or an insulator will increase the transfer of heat from the case to the heat sink.

$R_{th(s-a)}$, which is thermal resistance from heat sink to the ambient, is based on heat sink emissivity and airflow over the heat sink to carry the heat away. The heat sink to ambient heat flow is dependent on the ability of the surrounding ambient media to absorb the heat.

The total $R_{th(j-a)}$ thermal resistance is expressed as:

$$R_{th(j-a)} = R_{th(j-c)} + R_{th(c-s)} + R_{th(s-a)}$$

The maximum power that a given package can handle is given by:

$$P_D = \frac{T_{j(max)} - T_{amb}}{R_{th(j-a)}}$$

Microminiature, low power consumption, low dropout regulator

SA57001-XX

DEFINITIONS

Line regulation is the change in output voltage caused by a change in input line voltage. This parameter is measured using pulse measurement techniques or under conditions of low power dissipation so as to not significantly upset the thermal dynamics of the device during test.

Load regulation is the change in output voltage caused by a change in output load current and is measured in a manner which will not cause significant heating of the device during test.

Quiescent current is that current which flows to the ground pin of the device when the device is operated with no output current flowing.

Ground current is that current which flows to the ground pin of the device when the device is operated with output current flowing due to an applied load. It is the measurement difference of input current minus the output current.

Dropout voltage is the input/output differential voltage at which the regulator ceases to maintain specified output regulation if the input voltage is reduced. It is highly influenced by device junction temperature and load current.

Output noise is the integrated output noise voltage specified over a frequency range and expressed in nV/kHz or V_{rms} . It is measured with the input voltage and output load current held constant during test.

Current limiting is internal device circuitry incorporated to limit the output current of the device. This feature is incorporated in the device to protect the device against output over current conditions or output shorts to ground.

Thermal shutdown is internal device circuitry incorporated in the device to shut down the device when the chip temperature reaches a specified temperature. This feature protects the device from excessive operating temperatures that would otherwise be catastrophic to the device. Over heating can be created by accidental output shorts.

TEST CIRCUITS AND TEST SET-UP TABLES

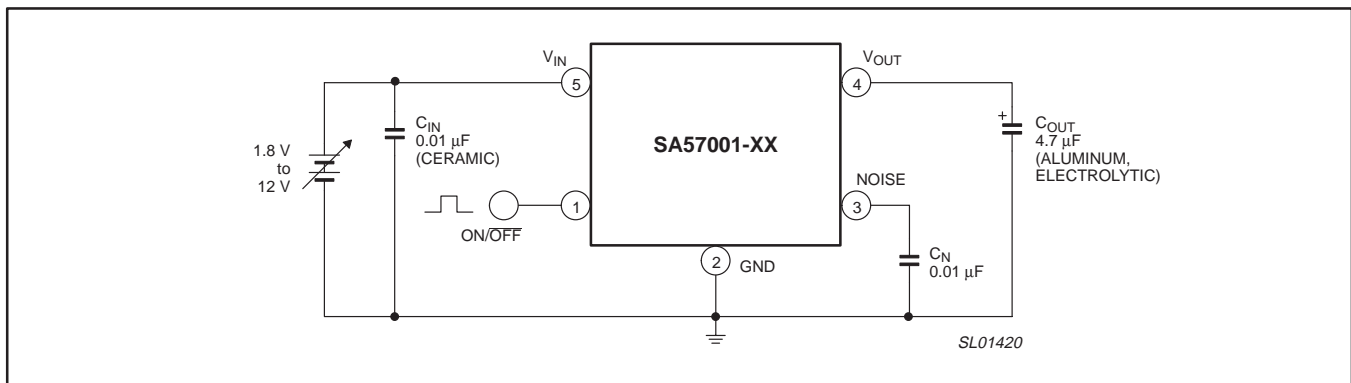

Figure 23. Test circuit 1.

Microminiature, low power consumption, low dropout regulator

SA57001-XX

PACKING METHOD

The SA57001-XX is packed in reels, as shown in Figure 24.

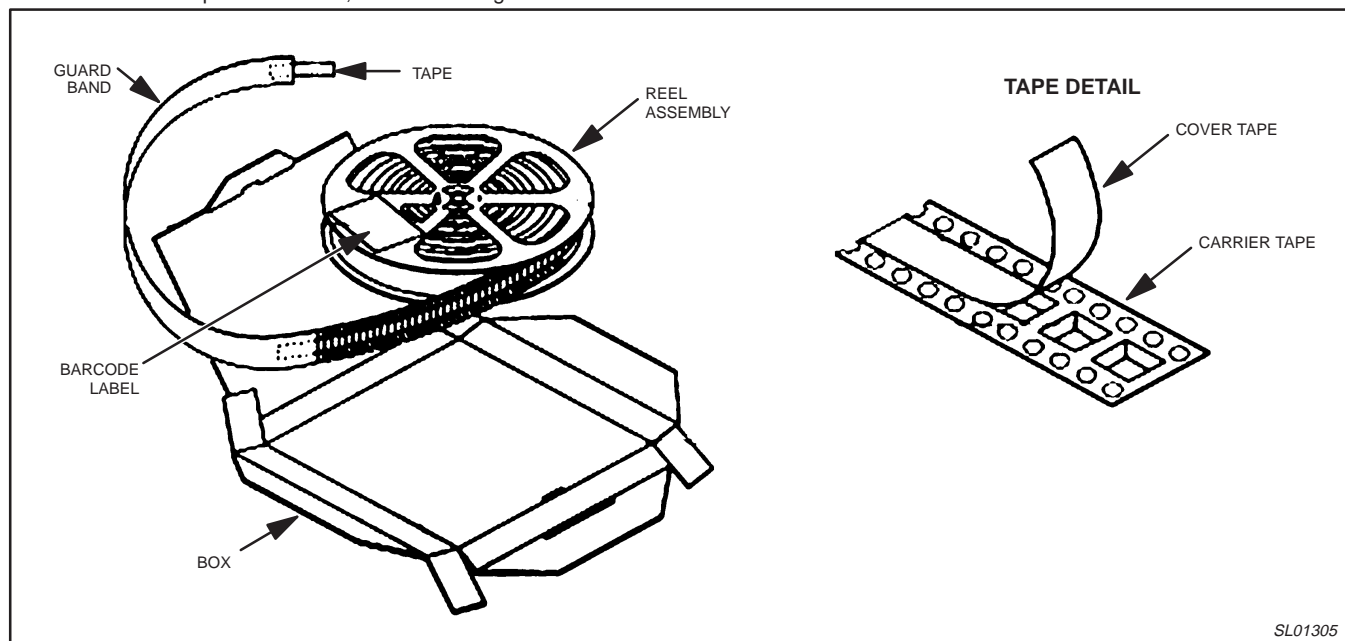

Figure 24. Tape and reel packing method

SL01305

Microminiature, low power consumption,
low dropout regulator

SA57001-XX

Plastic small outline package; 5 leads; body width 1.6 mm

SOP003

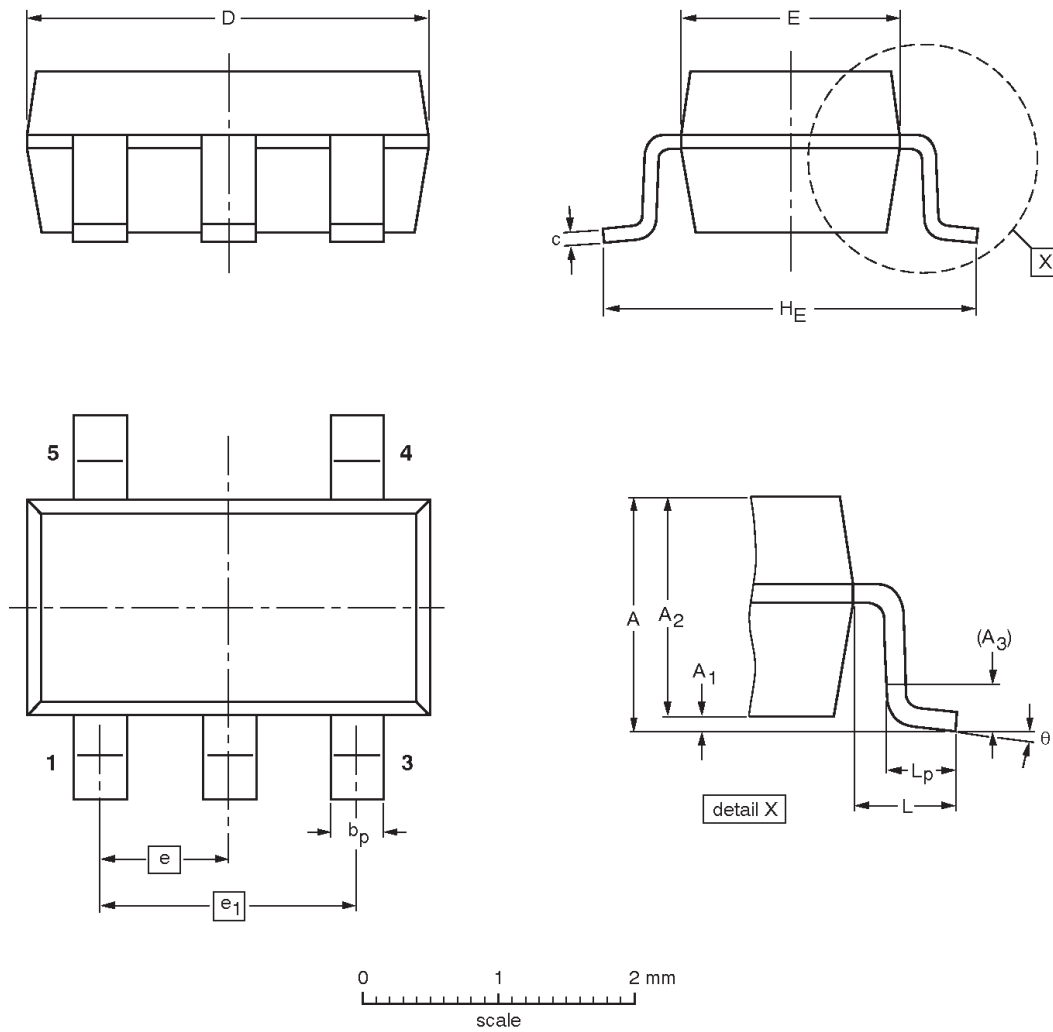

DIMENSIONS (mm are the original dimensions)

UNIT	A max.	A ₁	A ₂	A ₃	b _p	c	D ⁽¹⁾	E ⁽²⁾	e	e ₁	H _E	L	L _p	θ
mm	1.35	0.15 0.05	1.2 1.0	0.25	0.50 0.25	0.22 0.08	3.0 2.7	1.7 1.5	0.95	1.9	3.0 2.6	0.6	0.55 0.35	8° 0°

Notes

1. Plastic or metal protrusions of 0.15 mm maximum per side are not included.
2. Plastic or metal protrusions of 0.25 mm maximum per side are not included.

OUTLINE VERSION	REFERENCES				EUROPEAN PROJECTION	ISSUE DATE
	IEC	JEDEC	JEITA			
SOP003		MO-178				03-06-25 03-10-07

**Microminiature, low power consumption,
low dropout regulator**

SA57001-XX

REVISION HISTORY

Rev	Date	Description
_3	20031016	Product data (9397 750 11881); ECN 853-2274 30176 of 01 August 2003. Supersedes data of 2003 Mar 20 (9397 750 11127). Modifications: <ul style="list-style-type: none">• Add 'Marking code' table to Ordering Information section on page 3.• Change package outline to SOP003.
_2	20030320	Product data (9397 750 11127); ECN 853-2274 29154 of 06 November 2002. Supersedes data of 2001 Aug 01 (9397 750 08717).
_1	20010801	Product data (9397 750 08717); ECN 853-2274 26807 of 01 August 2001.

Microminiature, low power consumption, low dropout regulator

SA57001-XX

Data sheet status

Level	Data sheet status ^[1]	Product status ^{[2] [3]}	Definitions
I	Objective data	Development	This data sheet contains data from the objective specification for product development. Philips Semiconductors reserves the right to change the specification in any manner without notice.
II	Preliminary data	Qualification	This data sheet contains data from the preliminary specification. Supplementary data will be published at a later date. Philips Semiconductors reserves the right to change the specification without notice, in order to improve the design and supply the best possible product.
III	Product data	Production	This data sheet contains data from the product specification. Philips Semiconductors reserves the right to make changes at any time in order to improve the design, manufacturing and supply. Relevant changes will be communicated via a Customer Product/Process Change Notification (CPCN).

[1] Please consult the most recently issued data sheet before initiating or completing a design.

[2] The product status of the device(s) described in this data sheet may have changed since this data sheet was published. The latest information is available on the Internet at URL <http://www.semiconductors.philips.com>.

[3] For data sheets describing multiple type numbers, the highest-level product status determines the data sheet status.

Definitions

Short-form specification — The data in a short-form specification is extracted from a full data sheet with the same type number and title. For detailed information see the relevant data sheet or data handbook.

Limiting values definition — Limiting values given are in accordance with the Absolute Maximum Rating System (IEC 60134). Stress above one or more of the limiting values may cause permanent damage to the device. These are stress ratings only and operation of the device at these or at any other conditions above those given in the Characteristics sections of the specification is not implied. Exposure to limiting values for extended periods may affect device reliability.

Application information — Applications that are described herein for any of these products are for illustrative purposes only. Philips Semiconductors make no representation or warranty that such applications will be suitable for the specified use without further testing or modification.

Disclaimers

Life support — These products are not designed for use in life support appliances, devices, or systems where malfunction of these products can reasonably be expected to result in personal injury. Philips Semiconductors customers using or selling these products for use in such applications do so at their own risk and agree to fully indemnify Philips Semiconductors for any damages resulting from such application.

Right to make changes — Philips Semiconductors reserves the right to make changes in the products—including circuits, standard cells, and/or software—described or contained herein in order to improve design and/or performance. When the product is in full production (status 'Production'), relevant changes will be communicated via a Customer Product/Process Change Notification (CPCN). Philips Semiconductors assumes no responsibility or liability for the use of any of these products, conveys no license or title under any patent, copyright, or mask work right to these products, and makes no representations or warranties that these products are free from patent, copyright, or mask work right infringement, unless otherwise specified.

Contact information

For additional information please visit
<http://www.semiconductors.philips.com>. Fax: +31 40 27 24825

© Koninklijke Philips Electronics N.V. 2003
All rights reserved. Printed in U.S.A.

Date of release: 10-03

For sales offices addresses send e-mail to:
sales.addresses@www.semiconductors.philips.com

Document order number: 9397 750 11881

Let's make things better.